



# BWC XL.50

## 50 kW CLASS WIND TURBINE

- 5-YEAR WARRANTY
- EXCEPTIONAL LOW WIND PERFORMANCE
- SIMPLE DESIGN - 3 MOVING PARTS
- 5-YEAR MAINTENANCE INTERVAL
- STATE-OF-THE-ART AIRFOIL (PAT. PENDING)
- DIRECT-DRIVE NEODYMIUM PM ALTERNATOR
- AUTOFURL AUTOMATIC STORM PROTECTION
- TOWERS FROM 28 - 82 M (92 - 267 FT)
- ON-GRID, UPS-MODE, AND OFF-GRID CAPABLE
- UL CERTIFIED TO IEC 61400-1 (PENDING)
- PART OF US-DOE "ADVANCED SMALL WIND TURBINE" PROGRAM

Available Spring, 2001

The new Bergey BWC XL.50 brings the benefits of wind power to areas with lower average wind speeds. It combines the famous Bergey Windpower ruggedness with new blade and alternator technology and very tall towers to provide a break-through in distributed wind power economics.

The BWC XL.50 utilizes a customized ABB variable speed drive to provide 480 VAC, 3-phase output in both on-grid and off-grid applications. With the addition of a 600 VDC battery bank it can operate as a 70 kW UPS or autonomous wind/diesel system.

The XL.50 is best suited for small businesses in high electricity cost areas and for larger remote facilities and villages.



ABB ACS 611  
Power Processor  
AC output at  
480 VAC,  
3-Phase,  
Grid-Connected  
or Off-Grid

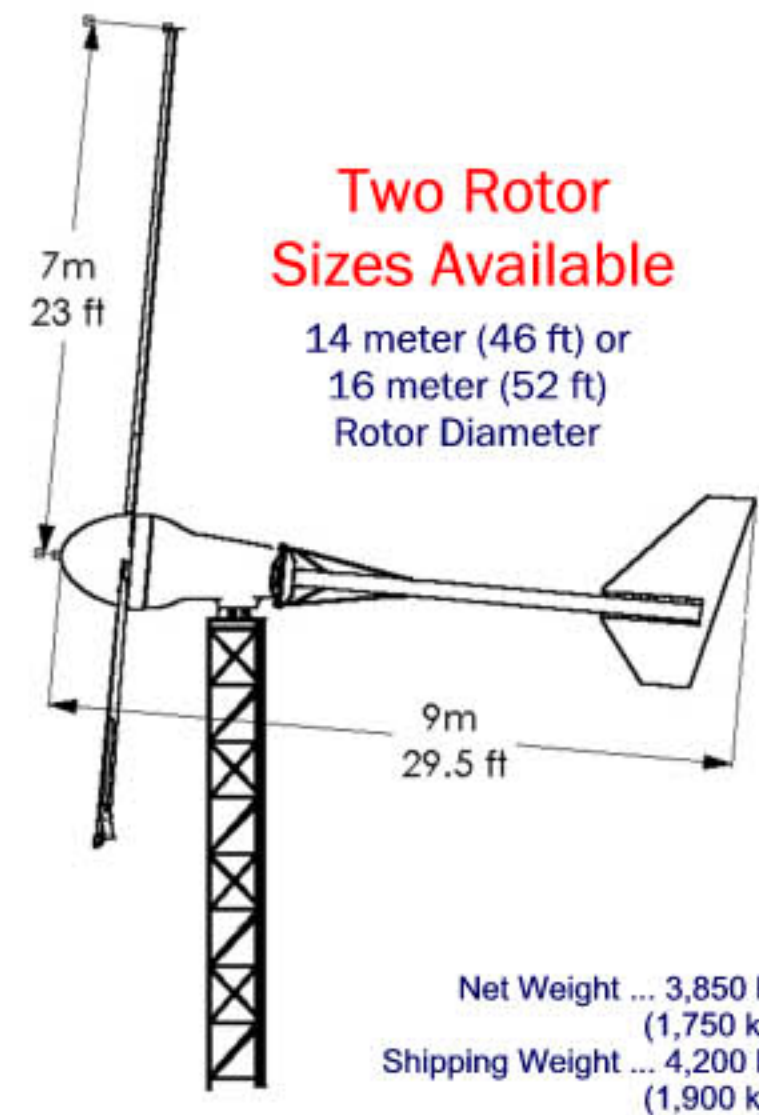

### THE ONLY MOVING PARTS ARE THE PARTS YOU SEE MOVING

#### Performance

Start-up Wind Speed ... 6.7 mph (2.5 m/s)  
 Cut-In Wind Speed ... 4.5 mph (2 m/s)  
 Rated Power ... 50 kW  
 Rated Wind Speed ... 25 mph (11 m/s)  
 Rated Rotor Speed ... 110 RPM  
 Furling Wind Speed ... 27 mph (12 m/s)  
 Max. Design Wind Speed ... 157 mph (70 m/s), 134 mph (60 m/s) for the 16 m rotor

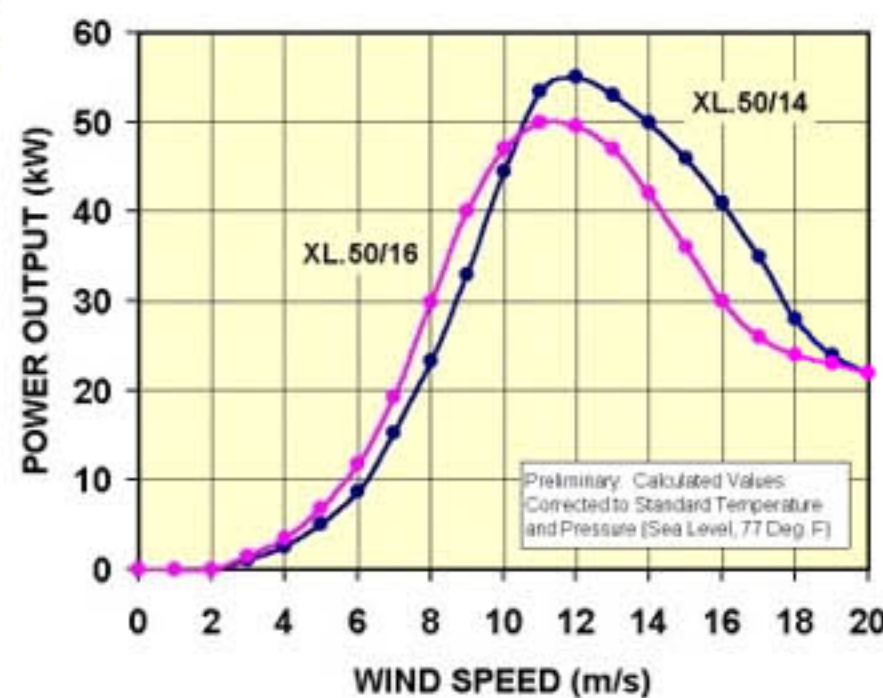

**BERGEY DIRECT**  
 www.bergey.com

#### Predicted Monthly Energy Production

##### Wind Speeds Taken at Top of Tower

Average Wind Speed	3 m/s	4 m/s	5 m/s	6 m/s	7 m/s	8 m/s
XL.50/14 (kWh)	1,400	3,600	6,800	10,300	13,700	16,500
XL.50/16 (kWh)	1,900	4,500	8,100	11,700	14,700	17,000

##### Wind Speeds Taken at 10 meters (per standard wind resource maps)

Average Wind Speed	3 m/s	4 m/s	5 m/s	6 m/s	7 m/s	8 m/s						
28 m Tower	50/14: 2,600	50/16: 3,400	6,100	7,400	10,500	11,700	14,500	15,300	17,400	17,700	18,900	18,900
40 m Tower	50/14: 3,200	50/16: 4,100	7,200	8,600	11,900	13,100	15,700	16,400	18,300	18,400	19,600	19,100
52 m Tower	50/14: 3,700	50/16: 4,600	8,100	9,500	12,900	14,000	16,600	17,100	18,900	18,700	19,800	19,200
82 m Tower	50/14: 4,700	50/16: 5,800	9,800	11,100	14,700	15,500	18,000	18,100	19,500	19,100	19,800	19,000

Assumptions: Inland Site, Rayleigh Distribution, Shear Exponent = 0.18, Altitude = 300 m  
 Your Performance May Vary.



**SIMPLICITY • RELIABILITY • PERFORMANCE**

2001 PRIESTLEY AVE.  
 NORMAN, OK 73069  
 T: 405-364-4212  
 F: 405-364-2078  
 SALES@BERGEY.COM

**WWW.BERGEY.COM**